

**SPECIFICATIONS**  
**1970**  
**MANUAL**

**MUSTANG • COUGAR**

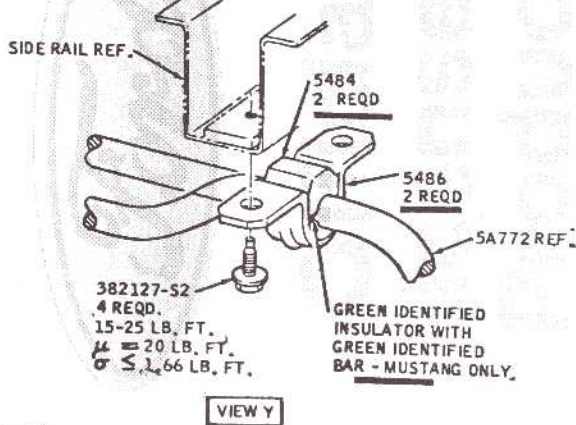

5A775 MUSTANG  
5A775 COUGAR

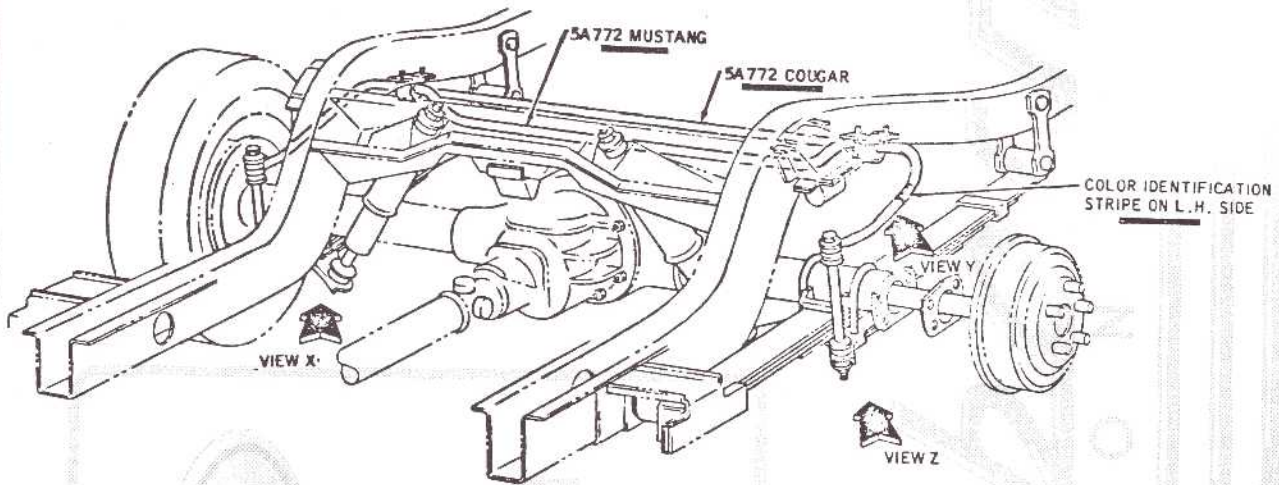
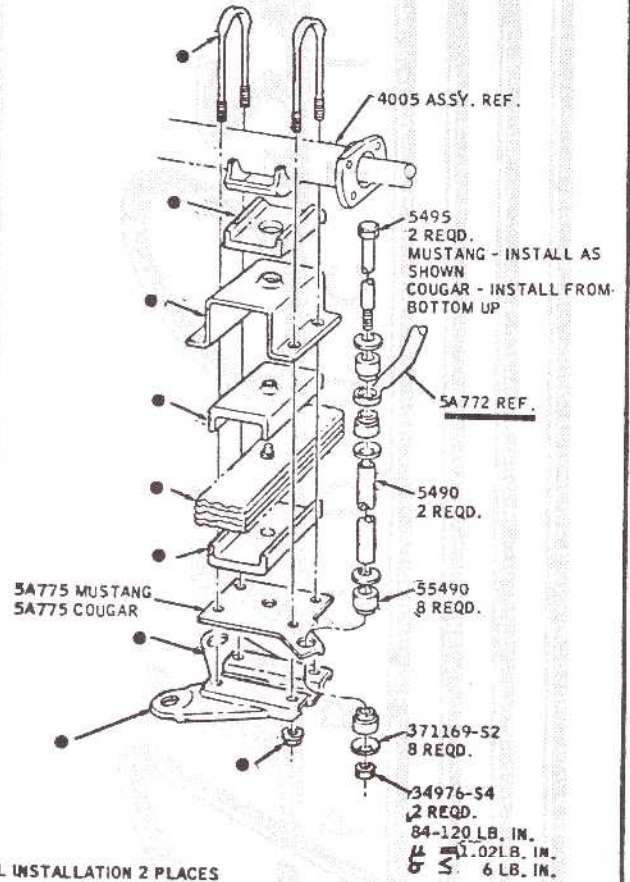

TYPICAL INSTALLATION 2 PLACES

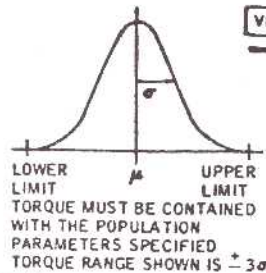

● FOR PART NUMBERS NOT SHOWN AND/OR COMPLETE INSTALLATION OF REAR SUSPENSION SEE SECT. 1 PAGE NO. 5-2

— DESIGNATES LATEST ENGINEERING CHANGES

FOR LATEST PREFIX AND SUFFIX SEE ENGINEERING PARTS LIST

1970 MUSTANG & COUGAR  
302-4V H.O., 351-2V, 351-4V  
390-4V & 428-4V C.J. ENGINES

INSTALLATION - REAR SUSPENSION  
MAXIMUM HANDLING